

TM-2™, TM-2-CG™ TM-4™, TM-4-CG™

DUCTED, DISPOSABLE CEILING FILTER MODULES

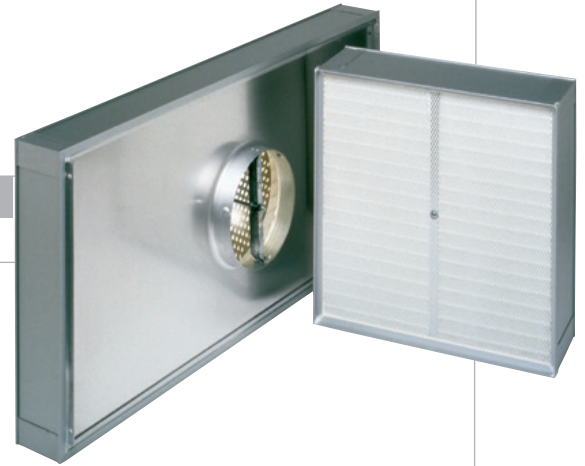

- Lightweight — easy to install
- White urethane sealant complies with Underwriters Laboratories, Inc. UL-586 and UL-900 Class 1
- One piece top with integral inlet collar
- Module assembled without screws or other fasteners — no metal shavings or filings
- Factory scan tested
- Suitable for gasketed and gel grid systems

The TM-2 and TM-4 ducted modules are lightweight, disposable HEPA filter ceiling modules. Both are designed for optimum filter performance in cleanrooms with individually ducted modules.

The TM-2 is a commercial, cost efficient filtration module for Class 100,000 to Class 10 cleanrooms. It is ideally suited for electronics, healthcare, food processing industries, or other applications where clean air quality is a priority.

The TM-4 is a superior air filtration module designed for Class 100 to Class 1 cleanrooms that demand higher efficiency. TM-4 modules are also suitable for applications requiring lower pressure drop than conventional ducted modules.

All standard TM-2 and TM-4 modules come with either a 10" or 12" diameter inlet (with special size inlets available). Both have an adjustable distribution plate, which can be adjusted with a screwdriver from the room side through an access port located in the center divider of the module. An optional design with a fixed perforated distribution plate is also available (center divider with access port not included).

All standard modules come with an integral expanded metal painted face grille. A contractor grade of both models is available with the same options.

Sturdy, Lightweight Housing

Both the TM-2 and TM-4 modules come in a variety of sizes, offering flexibility for any installation. The TM-2 24" x 24" module weighs 14 pounds and the 24" x 48" size weighs 24 pounds. The TM-4 weighs 26 pounds and 42 pounds, respectively. The two larger sized modules weigh substantially less than competitive units.

With the AAF TM-2 and TM-4 modules, the possibility of bypass leakage is virtually eliminated. All metal to metal joints are bonded to prevent leakage. Plus, each unit is entirely factory-sealed, so there are no leak paths between the filter inlet and air leaving side.

One room side air sampling port allows for checking of static pressure or contamination levels of the air entering the module. The same port is also used to adjust the damper-diffuser. Housings are available with four suspension points for attachment of hangers.

TM-2™, TM-2-CG™, and TM-4™, TM-4-CG™

AstroCel® II LPD Series Mini-Pleat Filter Optimizes Capture, Minimizes Resistance, and Reduces Costs

The media in each AstroCel II LPD Series filter is made of glass microfibers formed into a .015" thick mat pleated to allow a large amount of media surface area to be incorporated within the housing. The pleats are spaced with narrow ribbons of filter media, allowing the air to flow through the filter pack with minimum resistance. These ribbons make it possible to have a high performance media pack from 2" to 4" deep. The pack is sealed inside the housing on all four sides with a white urethane sealant that eliminates voids and leakage.

The airflow, initial resistance, and service life of the 2" mini-pleat media pack will outperform conventional 6" HEPA filters made with corrugated aluminum, nearly two to one.

Construction Detail

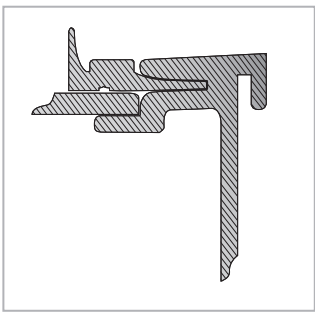

TM-2™ or TM-4™ with Seismic Hanger

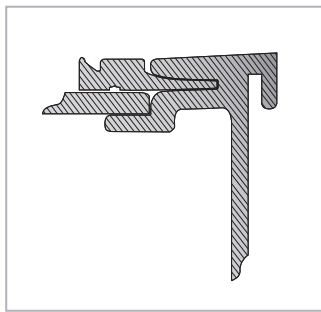

TM-2™ or TM-4™ without Hanger

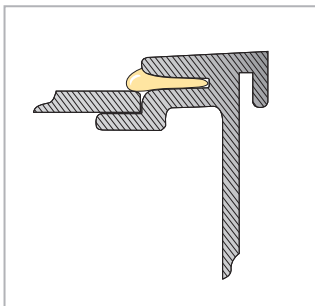

TM-2-CG™ or TM-4-CG™ (Gasket Seal Modules include Seismic Hangers)

Ease of Installation

The low profile housing and light weight of the TM-2 and TM-4 modules make installing them the easiest of any ceiling modules on the market.

The modules are typically installed in a 1¾" or 2" T-bar ceiling grid or 2" wide gel or gasket seal, heavy-duty ceiling grids, suspended from the building structure. Simply set the unit in place in the ceiling grid, then connect and seal the flexible supply air duct to the inlet collar. Dimples on the inlet collar prevent the flex duct from slipping off. No hold-down clamping is necessary between the filter and the ceiling grid. Modules can be accessed from the room side of the ceiling grid.

When the maximum design resistance has been reached, the entire module is simply discarded. This eliminates the time-consuming task of removing, replacing, and resealing filter cartridges. When a MEGApleat M8 filter is used in combination with other AAF filters, your total cost of ownership is less than competitive systems, as seen in the graph below.

Efficiency Selection

Choose from a variety of efficiencies:

HEPA Filter — 99.99% on .30 micrometer particles

ULPA Filter — 99.9995% on .10 to .20 micrometer particles

Application specific efficiencies available.

TM-2 Features

- Low Profile Housing (5" Gasket, 5¾" Gel)
- Two inch Filter Pack Depth
- Lightweight, Disposable Module
- AstroCel II Mini-pleat Filter Pack
- Gasket or Gel Seal Installation Options
- Contractor Grade Available (TM-2-CG)

The AAF TM-2 series, with its mini-pleat pack, is a commercial, cost efficient performer that delivers peak filtration in unidirectional and nondirectional flow cleanrooms from Class 100,000 to Class 10. Its lightweight, disposable design, ease of installation, and efficiency options make it ideal for applications where it is important to regulate the quality of air.

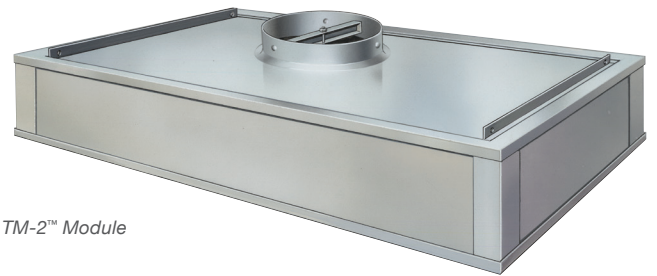

TM-2™ Module

TM-4 Features

- Low Resistance, High Airflow
- Low Profile Housing (7" Gasket, 7¾" Gel)
- Choice of Filter Pack Depth (2½", 3", 3½", 4")
- Gasket or Gel Seal Installation Options
- Contractor Grade Available (TM-4-CG)

The AAF TM-4 series, with its deep-pleat pack, was developed to meet industry requirements for large cleanrooms with individually ducted modules. This superior efficiency module reduces operating energy costs without compromising the demand for optimum filter performance. The TM-4 is available with custom efficiencies ranging up to 99.999995% on .10 to .20 micrometer size particles, making it ideal for Class 1 Waferfabs.

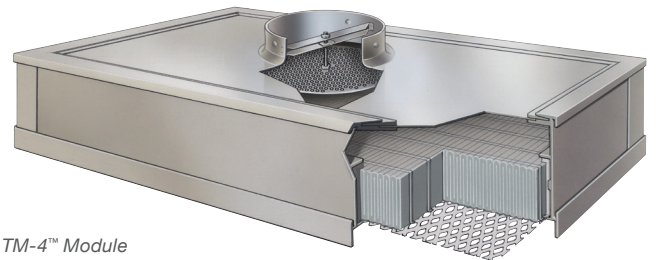

TM-4™ Module

TM-2™, TM-2-CG™, and TM-4™, TM-4-CG™

Product Information

Size vs. Rated Airflow @100 FPM Face Velocity¹

			Gel Seal Type ² with ¾" Skirt		2" H.D. Gasketed ² Grid Type		1½" Gasketed Grid ² Type	
TM-2 TM-2-CG Series	TM-4 TM-4-CG Series	Nominal Size (in.)	Actual Size (In.)	CFM	Actual Size (in.)	CFM	Actual Size (in.)	CFM
TM-2-43	TM-4-4	24 x 24	23 x 23	315	23¼ x 23¼	325	23⅝ x 23⅝	335
TM-2-63	TM-4-6	24 x 36	23 x 35	495	23¼ x 35¼	505	23⅝ x 35⅝	520
TM-2-73	TM-4-7	24 x 42	23 x 41	590	23¼ x 41¼	600	23⅝ x 41⅝	615
TM-2-83	TM-4-8	24 x 48	23 x 47	680	23¼ x 47¼	690	23⅝ x 47⅝	710

¹Factory airflow/resistance test is volumetric and determined by multiplying net free area of filter pack by 100 CFM/sq. ft.

²Sizes shown are typical. Check size to that recommended by ceiling grid manufacturer.

Performance Data

Filter Pack Resistance Data²

Performance Classification	ModulePack Efficiency Rating	Resistance @ 100 FPM (In. W.G.) Nominal Filter Pack Depth				
		2"*	2½"	3"	3½"	4"
		HEPA	99.99% @ .3 pm	.47	.38	.31
ULPA	99.9995% @ .1 to .2 pm	.68	.55	.46	.40	.32

²The resistance values shown may vary up to plus/minus 10%.

* Maximum pack depth available for TM-2™ Modules.



AAF has a policy of continuous product research and improvement and reserves the right to change design and specifications without notice.

ISO Certified Firm

©2015 AAF International

AFP-1-475H 03/15